

# DESICCANT DISPENSER

MODEL: 5D



# DESICCANT DISPENSER

## 5D TECHNICAL SPECIFICATION

Solid Models & Videos Available Online

The 5D desiccant dispenser is designed with you in mind. It is compact, easy to use, and affordable. The dispensing head is compact in size: only 178mm [7"] wide x 305mm [12"] high x 356mm [14"] deep. It is ideal for fitting in tight places. It's easy to use: just roll it up and plug it in. The unit self-threads itself with the automatic loading feature. It has diagnostics built into it along with a touch screen for easy setup. The cantilever design tractor drive system makes it easy to see how the machine is operating. At the same time, it is simple and easy to service.

The modular knife assembly is made from high grade tool steels, which gives you long life and reliable cutting. It is designed as a cartridge to be taken out without tools. The knife cartridge can be easily replaced within 30 seconds by any operator, no experience required.

Since this unit is so compact, it is easy to be put in tight places, providing the option to use multiple heads for higher production requirements. Using multiple heads gives an advantage because you can add more capacity to a line as your demands require, or they're easy to move from line to line, reducing your actual cost.

The unit only requires standard outlet power. It doesn't require compressed air, making it easy to set up and use. The machine is designed to run desiccants from all manufacturers, giving you the freedom of choice to get the most competitive pricing for your material.

## BENEFITS

- Tool-less changeover to different desiccant
- Touch screen for easy set up
- Cantilever design for complete access to the feeding process
- Knife cartridge – replacement under 30 seconds
- Compact in size: 178mm [7"] wide x 305mm [12"] high x 356mm [14"] deep

## SPECIFICATIONS

- Cycle rate: 100 cycles per minute, running 1 gm desiccant
- Requires 110 V AC or optional 230 V AC
- Pouch size limit 1 1/2" x 0.4" thick (38.1mm x 10.16mm)

## OPTIONS

- Stand
- Mounting to fit your application
- Unwind
- Bottle escapement
- Timing screw

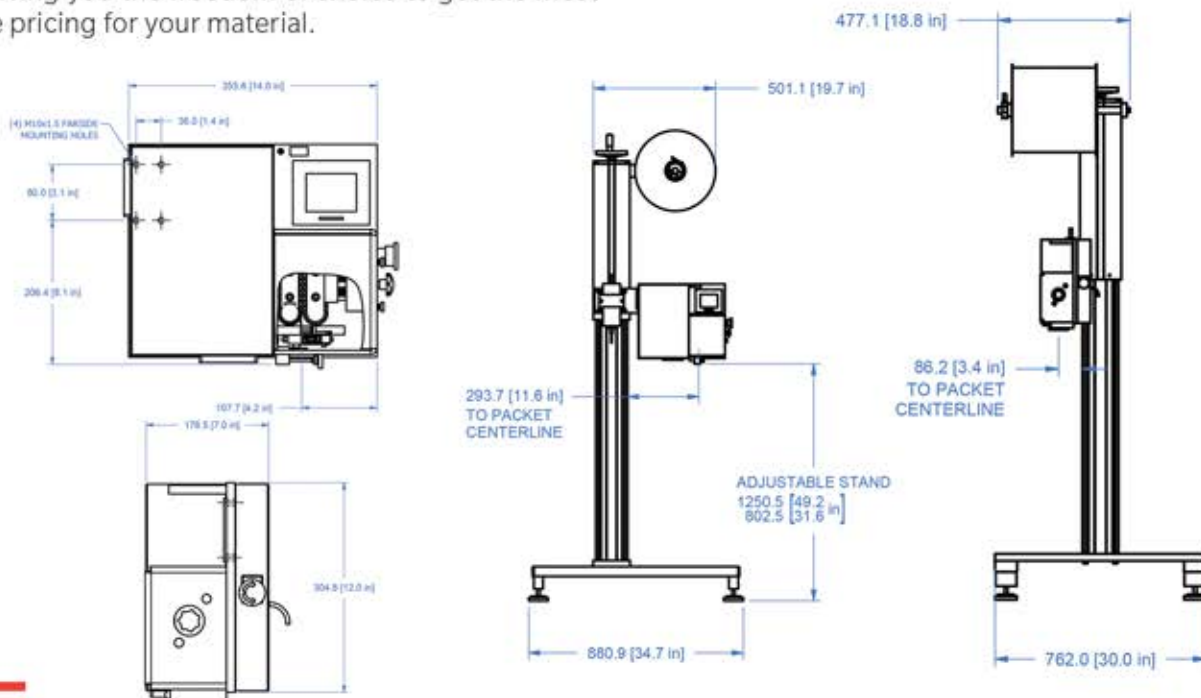

### WARNING:

EQUIPMENT MUST BE GUARDED IN ACCORDANCE WITH ALL FEDERAL, STATE, AND LOCAL REQUIREMENTS



CUSTOM FEEDING & CUTTING SOLUTIONS

26 Just Road, Fairfield, NJ, 07004 | 973-439-1428 | [azccorp.com](http://azccorp.com)



visit us online!

