

SUR-SIZE™ Sheeter

TS-54



FOR ALL YOUR FEEDING AND CUTTING NEEDS

26 Just Road, Fairfield, NJ 07004 | 973-439-1428 | azcocorp.com

SUR-SIZE™ Sheeter

TS-54

Technical Specification

This compact, economical sheeter is ideal for low speed applications. Installation is a breeze and setup is done in just a few easy steps. Simply place the material onto the unwind support, thread it through the roll feeders, and specify the cut length and quantity on the touchscreen. When ready, the SUR-CUT™ traveling knife assembly automatically cuts the material with exceptional precision, and with the addition of a slitter station, you can also cut the material into strips of a desired width.

Materials: films, foils, paper, non-wovens, corrugated

Specifications

- Cuts material up to 1372 mm/54" wide
- Power requirements: 110 V AC or 220 V AC
- 80 psi (5.5 bar) compressed air
- Accuracy: +/- 3.2 mm (0.13")
- Rate: adjustable from touchscreen

Options

- Slitter station
- No-product sensors
- Low-product sensors
- All electric model

TS-54

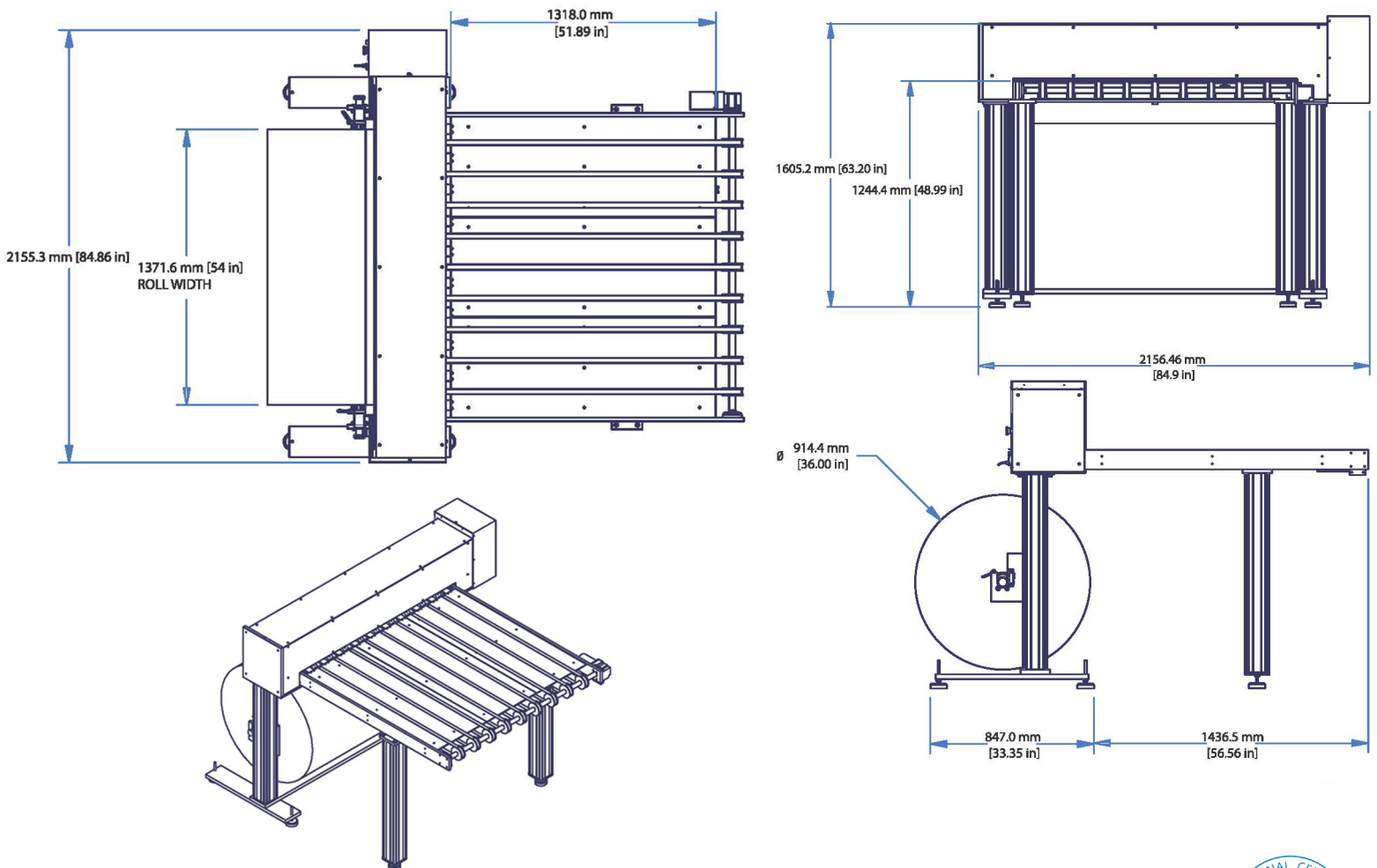

WARNING:

EQUIPMENT MUST BE GUARDED IN ACCORDANCE WITH ALL FEDERAL, STATE, AND LOCAL REQUIREMENTS



FOR ALL YOUR FEEDING AND CUTTING NEEDS

26 Just Road, Fairfield, NJ 07004 | 973-439-1428 | azcocorp.com

Visit us online

