

ADJUSTABLE STANDS

STYLE H



ADJUSTABLE STANDS

STYLE H, ADJUSTABLE STANDS

Solid Models Available Online

This module stand is designed so that equipment can be easily mounted onto it and is ideal for many applications.

A totally enclosed telescoping stand is rigidly constructed so there are no exposed mechanisms. Our stands have a load capacity of up to 1000 lbs and its cantilever design allows for cantilever thrust load capability.

The stand column is made from clear anodized aluminum with a steel weldment base. The steel weldment has leveling screws and castors for easy setup. The column comes with mounting holes to mount equipment onto it. An optional motorized version is also available, along with an encoder hand wheel for setting heights to repeated distances. Optional mounting plates along with XY axes can be added on to fit your configuration.

BENEFITS

- Enclosed mechanism
- Just-In-Time delivery
- Easily modified to your specifications
- Wash down design
- Heavy Duty and rigid
- Locking column

SPECIFICATIONS

- Adjusting screw with hand crank for height adjustments from 800mm/31.5" to 1200mm /47.2"
- Surface clear anodized aluminium
- Load capacity up to 1000 lb

OPTIONS

- Stainless steel base
- Locking casters
- Motorized adjustments
- X Y travel option
- Modified to meet your requirements

MOTORIZED STAND OPTION

- Power requirement: 110 V AC or 220 V AC
- Switch built into the column or connector to be controlled by customer
- Standard speed: 81.3mm / 3.2" per minute
- Customs on request

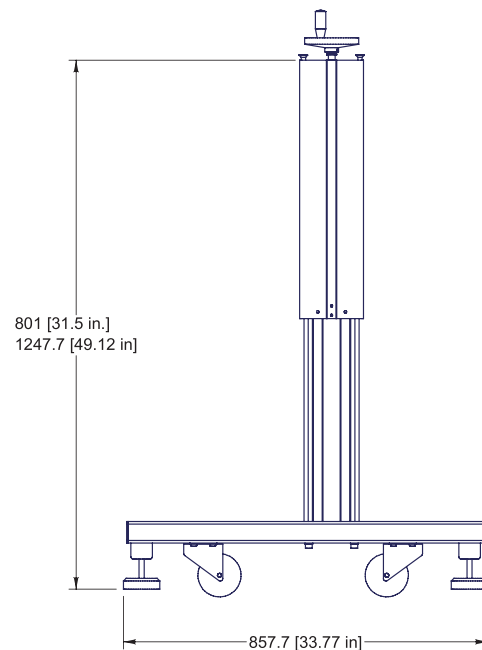
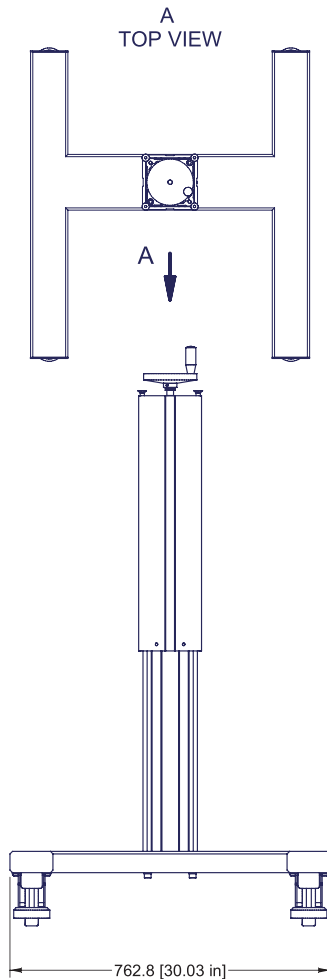

WARNING:

EQUIPMENT MUST BE GUARDED IN ACCORDANCE WITH ALL FEDERAL, STATE, AND LOCAL REQUIREMENTS



visit us online!



FOR ALL YOUR FEEDING AND CUTTING NEEDS

26 Just Road, Fairfield, NJ, 07004 | 973-439-1428 | azcocorp.com